



Digital panel meter modules

Data Sheet

RS stock number 313-479

OEM 24L

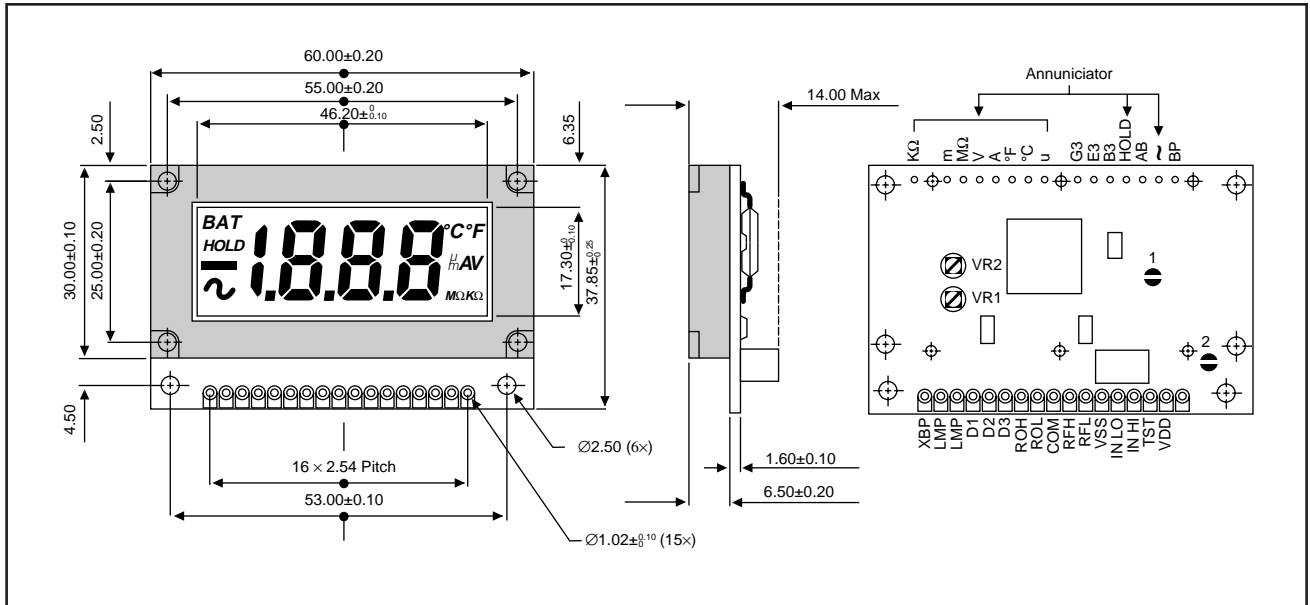

Features

- 3 1/2-digit 12.7mm character height display
- Display On-Hold option
- 200mA full scale input sensitivity
- 10pA input current typical
- Automatic polarity
- Automatic zero
- Easy to use decimal point and annunciators
- Reflective mode
- LED backlight.

Definition of terminals

Pin	Description
V _{DD}	Positive supply terminal
V _{SS}	Negative supply terminal for 9V option
INHI INLO	Positive input terminal Negative input terminal
RFH RFL ROH ROL	Reference input High terminal Reference input Low terminal Reference output High terminal Reference output Low terminal
MP	Backlight
COM	Analogue common
TST	TEST pin. Connect to V _{DD} for lamp LCD will be degraded if left at V _{DD} for several minutes This pin is also negative supply terminal for 5V operation

Pin	Description
XBP	For driving annunciators
BP	LCD back plane. All annunciators are tied to this pin on PC board
D1, D2, D3	Decimal point. D1 = 0.000, D2 = 0.00, D3 = 00.0. The decimal point will energise when these pins are tied to V _{DD} .
AB, B3, E3, G3	Segment for developing over and under range signal
BAT, °C, °F, ~, m, μ, MΩ, KΩ, V, A, HOLD2	Annunciators, BAT is auto turn on for these modules

Operating specifications

Operating temperature _____ °C to +50°C
 Storage temperature _____ -40°C to +70°C
 Operating relative humidity _____ 90% max.

Electrical characteristics (T_a = +25°C)

Parameter	Condition	Min.	Typ.	Max.	Unit
Supply voltage (V _{DD})	9V option	7.0	9.0	10.0	V
		4.8	5.0	6.0	V
Supply current (I _{DD})	9V option	-	300	500	μA
		-	5	-	mA
Leakage input current (I _{IL})		-	1	10	pA
Reference voltage (factory adjusted)	For 9V option only	-	100	-	mV
Full scale		-	-	199.9	mV
Zero input reading		-	+0.000	-	Count
Linearity (max. deviation from best straight line)	9V option	-	+0.2	+2	Counts
		-	+2	+4	Counts
Resolution		-	100	-	μV
Sampling rate		-	3	4	Read/Sec.
CMRR		-	70	-	dB
Temperature coefficient		-	100	150	ppm/°C
Low battery indicator	For 9V option only	6.75	7.25	7.75	V
Backlight current	Supply 5V	-	40	60	mA

5V/9V operating voltage configuration

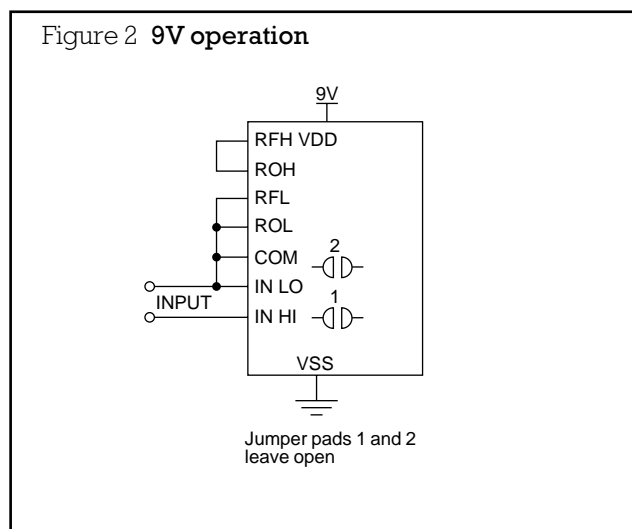
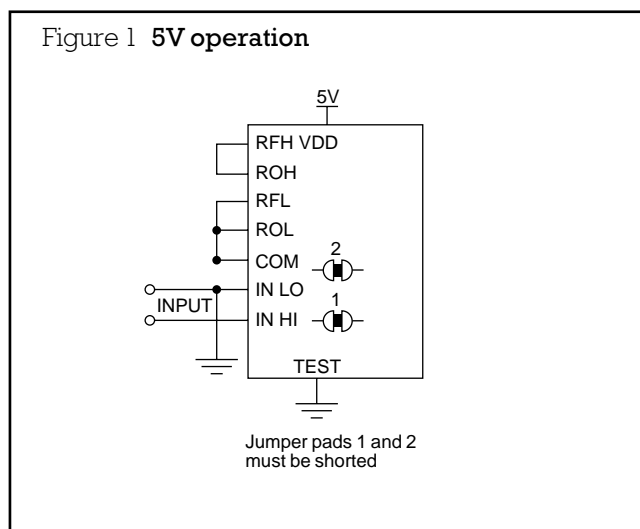
**Note:**

OEM24L is calibrated for 9V operation, for 5V operation, it has to be recalibrated. With 199mV on input, adjust VR1 to read 1990 on display.

Users' instructions

For normal operation the module should be connected as in Figure 1 or Figure 2. In this configuration the input range is set for 200mV full scale. If the input exceeds 200mV the module will go into an over-range condition. In this case the most significant digit will be a '1' and the rest will be blank. With a high input impedance, an over-range condition could occur with no signal applied. To avoid this and set the display to zero, connect a 10M Ω resistor across the input terminals.

The module has an automatic zero adjustment.

A minus sign is displayed to show reverse polarity between INHI and INLO. The input terminals must not be connected directly to either V_{DD} or V_{SS} , as this causes a latch up of the IC.

The unit is designed to operate with either a 5 or 9V supply. For 9V operation it is recommended that a battery is used. Normally the inputs would be floating with respect to the 9V supply. If not they should be between $V_{SS} + 1.5V$ and $V_{DD} - 1.5V$.

For 5V operation the module may need to be recalibrated. This is done by connecting the module as in Figure 1, then with 199.0mV applied to the inputs, adjust VR1 until the display reaches 1990. With 5V supply the input can be either floating or non-floating. The low battery annunciator can be turned off by adjusting VR2.

Application circuits

Input attenuator for $V_{IN} > 200mV$

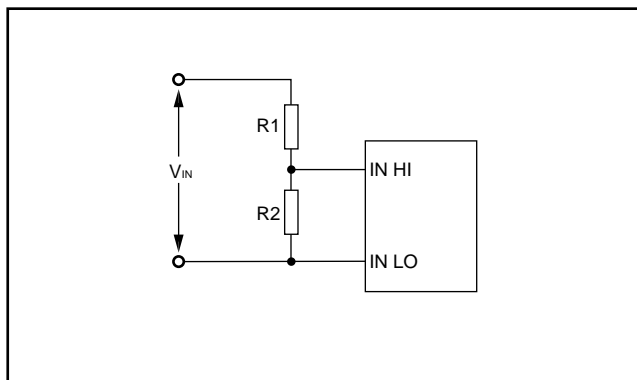

To measure voltages greater than 200mV an input attenuator is required, as shown above. This attenuator can also be used to adjust the meter scale factor. R1 and R2 should be accurate and stable. Good metal film resistors meet these requirements.

$$\text{Meter input} = \left(\frac{R_2}{R_1 + R_2} \right) \times V_{IN}$$

- eg. (i) for $V_{IN} = 2V$; $R_1 = 9M\Omega$, if R_2 is chosen to be $1M\Omega$.
- eg. (ii) to display the speed of a shaft rotating up to 1500rpm, using a tachogenerator having an output of 60Vdc per 1000rpm: The 90V output at 1500rpm must be reduced to 150mV to give a reading of 1500. If R_1 is chosen as $1M\Omega$, R_2 should theoretically be $1.669k\Omega$.

Current measurement

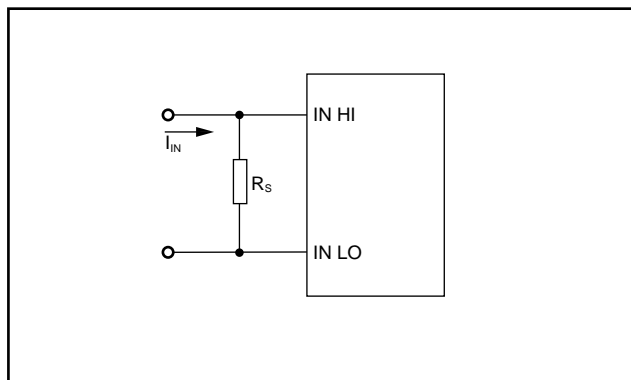

Current measurement requires a shunt resistor (R_S) to convert the input current into a 200mV input voltage as shown above. This shunt can also be used to adjust the meter scale factor.

$$\text{Meter input} = R_S \times I_{IN}$$

Note: Where I_{IN} is expressed in Amps Meter input will be in Volts. Similarly where I_{IN} is expressed in mA Meter input will be in mV.

- eg. (i) for $I_{IN} = 200mA$; $R_S = 1\Omega$. For higher currents (eg. 20A or 200A), special block shunts, having a 200mV output are available.
- eg. (ii) to display the level in a tank, as a percentage of its capacity, using a linear sensor having a 0mA output when empty and 5mA when full: R_S should then be 20Ω , which will convert the 0 to 5mA signal into a 0 to 100mV input. By selecting the appropriate decimal point, this can be displayed as 0 to 100.0%.

Multirange voltmeter

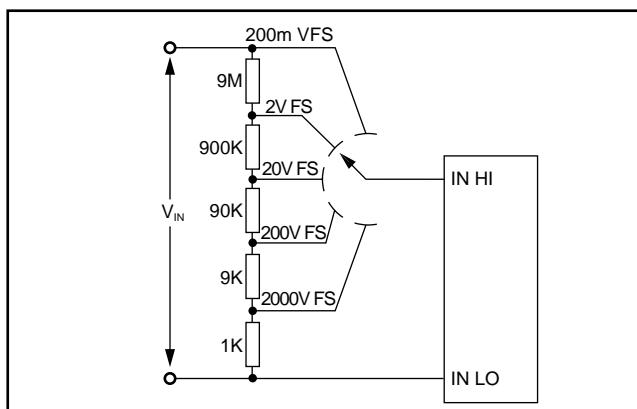

Multirange voltmeters are easy to implement using a rotary or push-button switch system as shown. It is necessary to also switch the decimal point. This can easily be accomplished by connecting the appropriate D1 to D3 terminals with a rotary switch to V_{DD} .

Multirange ammeter

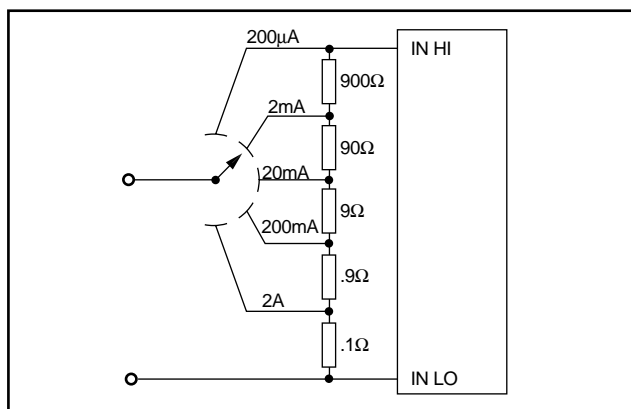

Multirange current meters can be produced using a rotary or push-button switch system as shown.

ac voltage measurements

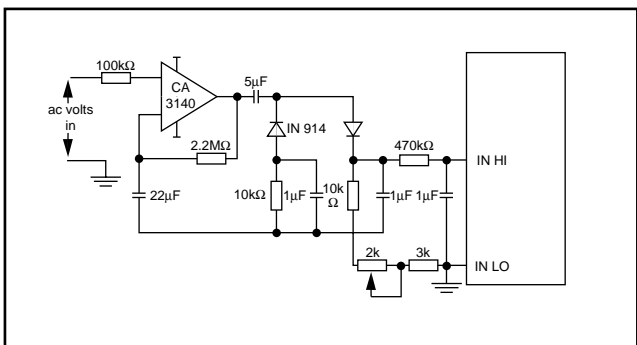

The module can only measure dc. The diagram above shows an ac to dc converter circuit that can be used to measure ac. Alternatively to measure true RMS the following ICs would be suitable. Please refer to the Semiconductors-Analogue/Linear ICs section of the RS Catalogue. AD636JH RS stock no. 302-665, AD736JN RS stock no. 658-328.

Auto-ranging

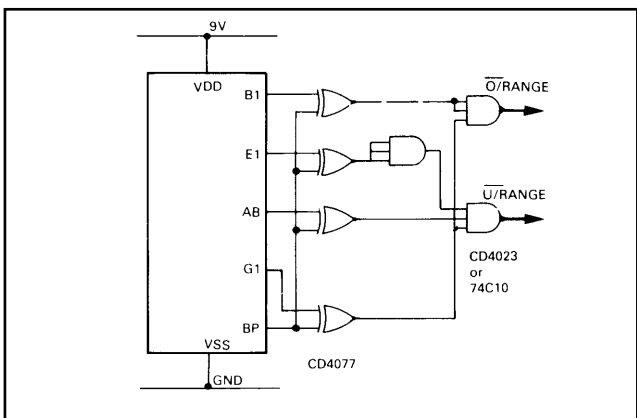

Connections for generating the over- and under-range signals for use in auto-ranging applications.

Note: Take power supply for external gates from V_{DD} and TST (not V_{SS}).

Resistance measurements

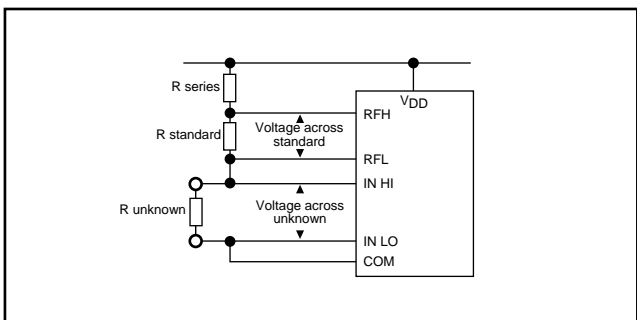

The ratiometric technique is used for resistance measurements. The unknown resistance is placed in series with a known resistor and current is passed through the pair. The voltage developed across the unknown resistor is applied to the input (INHI, INLO). The voltage across the known resistor is applied to the reference inputs RFH and RFL. If the unknown equals the standard, the display will read 1000.

$$\text{Displayed reading} = \frac{R_{\text{unknown}}}{R_{\text{standard}}} \times 1000$$

Due to the ratiometric technique, no accurately defined reference voltage is required. The module will over-range for $R_{\text{unknown}} \geq 2 \times R_{\text{standard}}$.

Note: R_{series} should be nominally 25 times R_{standard} within the limits $33k\Omega \leq R_{\text{series}} \leq 270k\Omega$.

Digital thermometer

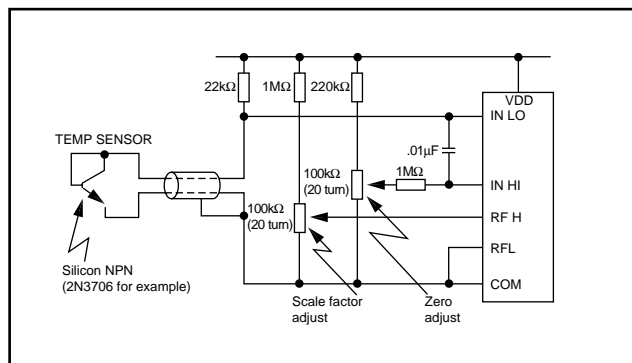

The sensing transistor has a temperature coefficient around -2mV/°C. To calibrate, place sensor in iced water (0°C) and adjust zero for a 000.0 reading. Then place sensor in boiling water (+100°C) and adjust scale factor for a 100.0 reading. The sensor would normally be built into a protective housing.

Note: This circuit does not use the internal reference, ROL and ROH should be left open.

Zero display for non-zero input voltage

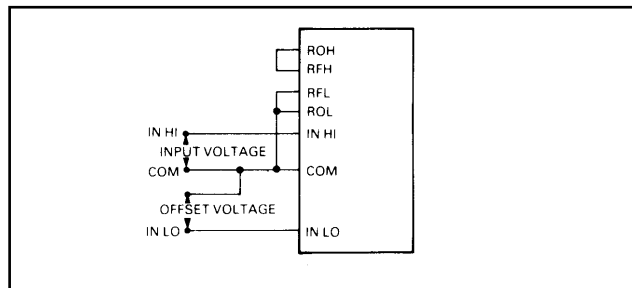

If a zero display is required when the input voltage level is not zero, the offset voltage should be connected between INLO and COM while the input voltage is connected between COM and INHI.

200mV full scale

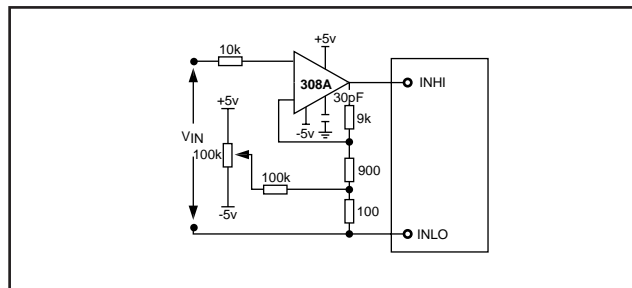

An operational amplifier is used to measure full scale voltages less than 199.9mV. Note that the auto-zero circuitry within the module cannot compensate for the op amp offset or voltage drift.

Mounting bezel (RS stock no. 260-353)

Available as an optional extra, the black ABS moulded bezel with clear acrylic window provides an attractive and convenient mounting method for the digital module.

The bezel is mounted through a single panel cut-out and the DPM module is attached to the bezel by 4 screws through the module mounting holes. Spring clips, retained by the screws, provide firm retention of the bezel/module assembly in the cut-out.

Bezel size _____ 64.5 × 34.5mm

Front projection from panel _____ 6mm max.

Panel cut-out _____ 63mm × 32.5mm

Max. panel thickness _____ 3mm

The information provided in **RS** technical literature is believed to be accurate and reliable; however, RS Components assumes no responsibility for inaccuracies or omissions, or for the use of this information, and all use of such information shall be entirely at the user's own risk.
No responsibility is assumed by RS Components for any infringements of patents or other rights of third parties which may result from its use.
Specifications shown in RS Components technical literature are subject to change without notice.